

# Safety Instructions for 140 Series Devices

## 141GP, 142AP, 143DP, 144FP, 144LVD, 144LD, 244LD, 244LVP

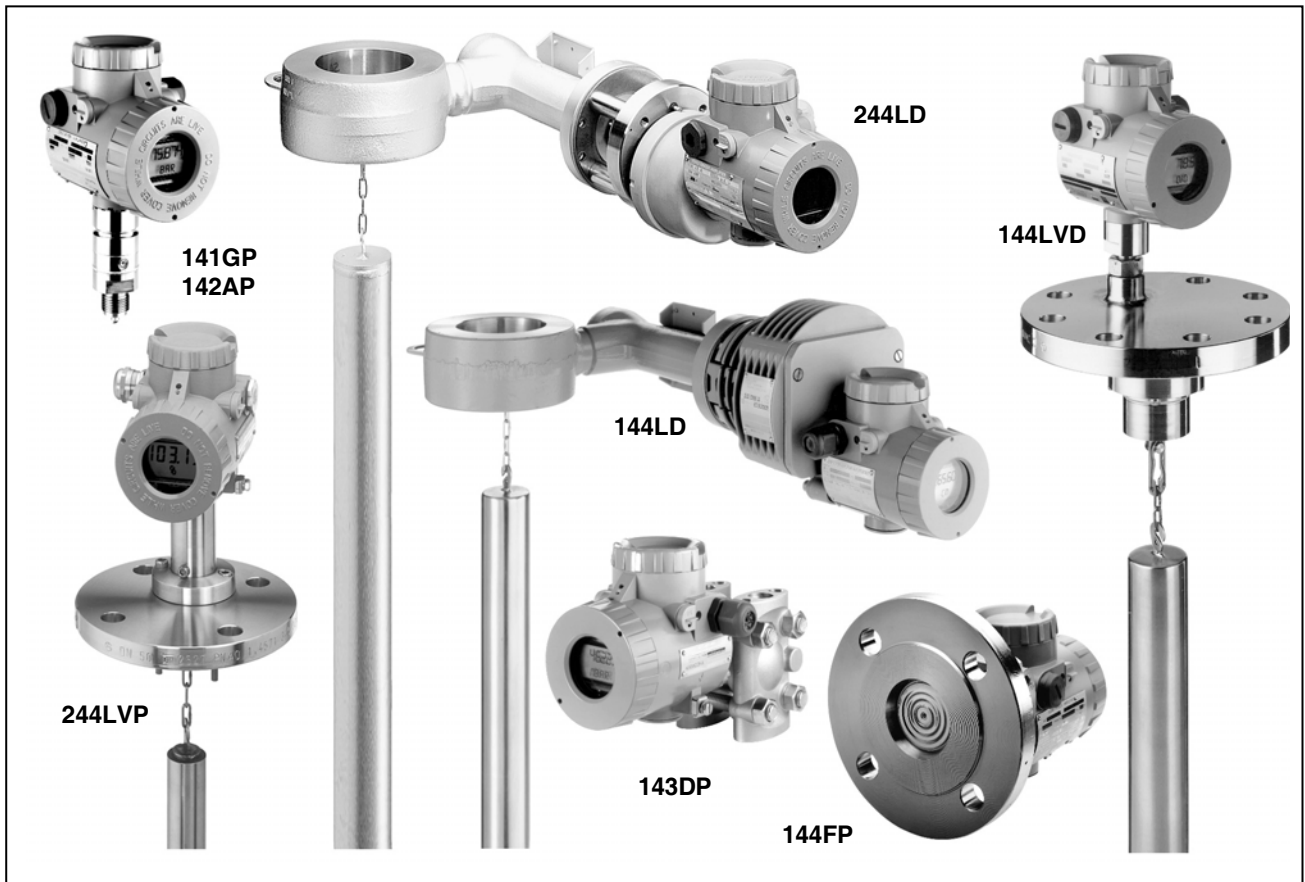

### for Measuring Amplifier and Measuring Sensor for Pressure

AI 408, AI 428, AID 421, AD 931, AT 421  
(intrinsically safe in HART / FoxCom / Profibus / Foundation Fieldbus, Flameproof and Dust Tight)

AI 416, AI 417, AI 418, AI 419, AI 432, AI 591, AD 402, AD 403, AD 404, AD 405, AD 406, AD 432

### Electrical Safety

Compliance with the essential Health and Safety Requirements EN 61010-1:2001, measurement category II and pollution degree 3.

Any work on electrical parts must be done only by qualified personnel, if any power supply is connected to the equipment.

The equipment components have to be used only according to their electrical data and for their designated purpose and have to be connected in accordance with their wiring diagrams.

Safety precautions taken in the equipment may be rendered ineffective if the equipment is not operated in accordance with Master Instructions.

Limitation of power supply for fire protection must be complied with according to EN 61010-1:2001, Chapter 9.6.

National application regulations for electrical equipment have to be adhered to.

The transmitters are suitable for use in potentially explosive atmospheres.

### Explosion Protection

Technical Data for explosion protection, see product specifications.

For equipment intended for use in potentially explosive atmospheres, all relevant national and installation regulations must be complied with, i.e. in Germany ElexV and EN 60079-14.

### Repair of Ex-Equipment

When repairing or altering explosion protection equipment, only manufacturer's original parts can be used. Repairs or alterations involving parts required for equipment for use in potentially explosive atmospheres, must either be carried out by the manufacturer or by a relevant authorised specialist or a relevant authorised certification body and certified by authorisation stamp or certificate.

**CE Identification**

Electromagnetic compatibility according to 89/336/EWG is ensured. Operating location is an industrial environment.

Pressure vessels and pressure holding equipment parts 144LD, 244LD, 167LP and their accessories are in compliance with Pressure Equipment Directive 97/23/EC.

**Mounting Location**

Protect transmitters against direct and extreme sun and/or heat exposure. The maximum permissible ambient temperature ranges have to be complied with.

**Type of Protection IP66**

To meet type of protection IP66 requirement, a correct installation of the cable glands and all O-rings has to be ensured.

**Decommissioning**

Prior to decommissioning take precautions to avoid operation disturbances:

- Comply with explosion protection
- Switch off power supply
- Caution with hazardous process media!
- Vessels/tube conduits must be depressurised
- With toxic, flammable or environmental harmful process media, observe relevant safety regulations.

**Process Media**

For dealing with process media comply with the relevant safety regulations.

Process temperature and thus housing temperature can be between -196°C and +500°C!

Caution: Danger of Injuries!

**Caution with Oxygen: Danger of Fire!**

Therefore special attention has to be paid for oxygen measurement:

- Use only transmitters suitable for oxygen measurement!
- Use only fittings free of oil and grease!
- Check whether all parts that may come in contact with oxygen are free of oil and grease!

**Recurring Checks**

The user has to ensure that the electrical process equipment is checked under the responsibility and supervision of an electro specialist, with respect to their proper condition of mounting, installation and operation, and this is required before the initial start-up and during specified intervals.

For pressure instruments we recommend (according to BetrSichV dated 27.09.2002) a check cycle of 2 years for the outer check, of 5 years for the inner check, and of 10 years for the resistance strength check. With corrosive and abrasive process media the check cycles have to be shortened.

**Combinations**

For equipment with explosion protection:

Our transmitters are assembled according to a modular design principle. The corresponding components are for multiple use and have each their own certificate for explosion protection.

The certificates are marked with a code (i.e. "AD 931"); these codes appear also on the labels and on the documents "Certificates of Conformity" (see also <http://www.foxboro-eckardt.com>).

As follows, the safety regulations of all certificates of this instrument family are listed. **Please comply with the safety regulations of your instrument version.**

Equipment	Type of protection		
	ia	d	la d
141GP	AI 416	AD 402	AD 402
142AP	AI 417	AD 403	AD 403
143DP	AI 417	AD 403	AD 403
144FP	AI 418	AD 404	AD 404
144LVD	AI 419	AD 406	AD 406
144LD	AI 591	AD 405	AD 405
244LD	AI 432	AD 432	AD 432
244LVP	AI 419	AD 406	AD 406
w. housing		AD 931	
HART/FoxCom T4	AI 408		
HART/FoxCom T6			AID 421
PROFIBUS			
Foundation Fieldbus	AI 428		

**AD 931 (EEx d) – see Label**

With "EEx d" certified equipment, the screw hole is ½ - 14 NPT or M20 x 1,5.

"EEx d" certified equipment must be connected by means of suitable cable entries or conduit systems, which meet the requirements of EN 50018 (March 1995) Part 13.1 and 13.2, and for which a separate certificate has been issued.

For cable entries or conduit systems (not included in delivery) the user assumes responsibility.

An opening not used must be sealed with a certified cover screw.

The housings of equipment with "EEx d" certificate must not be opened in potentially explosive atmospheres. This is not applicable only if instruments are not connected to any terminals or it is ensured that for the particular time there is no danger of explosion in the concerned areas.

With equipment with certificate "EEx ia d", the cover for the terminal box may be opened safety technically unrestricted. The user assumes responsibility.

With "EEx d" protection all housing covers and all securing screws have to be sealed and have to be secured against unintentional opening.

Attention: Impact test - The glass window of the electronics compartment cover passed the impact test at the low impact energy of 2 Joule.

**AI 428 (Profibus-Fieldbus) – see Label**

**Electrical Connections**

The bus wirings have to be lead onto the identified housing clamps, whereby no polarity has to be observed.

If the transmitter is operated in an interconnection with other instruments according to the FISCO model, the installation references according to the PNO-Manual for PROFIBUS PA, (Version 1.2/Outline) have to be complied with. If this is not the case, the rules for interconnection according to the PTB-Report PTB-ThEx-10 are applicable and have to be complied with.

**Electrical Data of the Transmitter AI 428**

Permissible ambient temperature range:

- 40°C to + 85°C at temperature class T4
- 40°C to + 65°C at temperature class T6

The transmitter, with reference to PNO-Outline chapter 2.1, can be used for connection to intrinsic safe supply circuits.

	Intrinsically safe ia/ib IIC, FISCO <sup>1</sup>	Intrinsically safe ia/ib IIB, FISCO <sup>1</sup>	Intrinsically safe ia/ib IIC, linear <sup>2</sup>
According to FISCO-Model	yes	yes	no
Max. Output Voltage U <sub>o</sub>	17.5 V	17.5 V	24 V
Max. Short Circuit Current I <sub>o</sub>	360 mA	380 mA <sup>3</sup>	250 mA
Max. Output Performance P <sub>o</sub>	2.52 W	5.32 W	1.2 W
<sup>1</sup> Supply instrument with rectangular or trapezoidal characteristics curve acc. to FISCO Model. <sup>2</sup> Supply instrument or barrier with linear characteristics curve. If a grounding of the barrier is necessary, only the input lead may be grounded. <sup>3</sup> The current limit value can be determined by assuming a rectangular characteristics curve.			

The transmitter AI 428 complies with the requirements of the FISCO model when connected to a FISCO supply instrument and for this reason, can be interconnected with other FISCO instruments when adhering to the installation guide.

or:

For connection to a certified intrinsically safe circuit with the following maximum values:

$$U = 24 \text{ V} \quad I = 380 \text{ mA} \quad P = 5.2 \text{ W}$$

**Electrical Data of the Sensor Element Circuit AI 428**

Sensor element circuit in type of protection EEx ia II C or EEx ib II C.

Max. Values:  $U = 7.93 \text{ V}$   
 $I = 9 \text{ mA}$   $C_o = 1.6 \mu\text{F}$   
 $P = 17 \text{ mW}$   $L_o = 1 \text{ mH}$

**Sensor Element Circuit:** (intrinsically safe)

Only for connection to certified intrinsic safe circuits of the category „ia“ or „ib“ with maximum values of the totals:

$$U = 60 \text{ V} \quad I = 150 \text{ mA}$$

Maximum Value of Power P / mW	max. Ambient Temperature °C		
	T6	T5	T4
75	65	80	115

**Mechanical Loading Capacity and Corrosion Resistance of the Membrane**

The explosion protection also depends on the density of the membrane of the measuring cell (rust free, corrosion resistant metals, membrane thickness > 0,06 mm). The transducer may therefore be used only for gases and liquids for which the membrane is sufficiently resistant chemically and resistant against corrosion.

Caution! The membrane has to be protected from mechanical influences.

AI 416 – AD 402 Measuring span (bar)	Overload limit (bar)	Safety limit (bar)
0.25 abs.	Pamb	50
2.5 abs.	4	200
25 abs.	50	200
0.25	1	50
2,5	5	200
25	50	200
250	375	500
1600	1800	2000

AI 417 – AD 403 Measuring span (mbar)	Overload limit (bar)			Safety limit (bar)
	M10	M12	7/16 UNF	
64	160	400	400	600
640	160	400	400	600
4000	160	400	400	600

AI 418 – AD 404 Measuring span (mbar)	Overload limit (bar)		Safety limit (bar)	
	P16	P40	P16	P40
64	16	40	24	60
640	16	40	24	60
4000	16	40	24	60

AI 419 – AD 406 Max. Force (N)	Overload limit max. (bar)	Safety limit (bar)
40	Up to 400	600
	500	600

**AI 419, AI 591, AI 432, AD 405, AD 406, AD 432**  
– see Label**Mounting on side of vessel (vessel extension)**

When used in Zone 0, fittings resistant to flame penetration must be used.

**Mechanics**

Displacers of more than 3 m length must be secured against oscillating when used in Zone 0.

When used as overfill protection according to VbF and/or WHG, the displacer must always be installed guided. Guide devices over 3 m length must also be secured against bending.

**Electrostatic Adhesion**

To avoid the danger of electrostatic ignition, a connection to the transmitter with good conductivity must be ensured. The volume resistance between the lower end of the displacer and the ground may not exceed  $10^6$  Ohm.

When used in Zone 0 and/or as overfill protection as per VbF, apart from displacers of metal only ones of PTFE + 25% carbon (surface resistance  $< 10^6$  Ohm) and com-posed moulded pieces may be used.

**Potential Equalization**

A potential equalization line must be mounted as an electrical bypass of the displacer suspension(s), if the residual displacer weight is  $< 10$  N or if more than 6 contact points are present.

**Cover Screws**

Ensure accurate and tight fitting of all cover screws!

**Flushing Connection**

If a flushing connection is welded to the pressure body, it has to be equipped with fittings resistant to flame penetration or completely sealed.

**Mounting of Sensor Elements**

To avoid contacts to earth during mounting or dismounting of the pressure sensor or the connection cables, these tasks have always to be done if the current supply is switched off.

Attention: The connection must be completely isolated from earth!

**AID 421 HART-FOXCOM (EEx ia d T6)**  
– see Label

If temperature class T4 is not sufficient and T6 is required, use the AID 421. The terminal compartment is intrinsically safe, whereas the electronics is located in the pressure containing housing. For this reason the electronics compartment, in contrast to the terminal compartment, must not be opened in potentially explosive atmospheres.

**AI 408 (HART-FoxCom)**

– see Label

For the connection of the intrinsically safe circuits the instructions of the EC Certificate of Conformity are valid.

**Electrical Data of Transmitter AI 408**

Permissible ambient temperature range:

–40°C to + 80°C at temperature class T4.

For connection to a certified intrinsically safe circuit with the following maximum values:

$U = 30$  V     $I = 150$  mA     $P = 0.9$  W

**Electrical Data of Sensor Element Circuit AI 408**

Sensor element circuit in type of protection EEx ia IIC or EEx ib IIC.

Maximum values:     $U = 30$  V  
                            $I = 9.5$  mA     $C_o = 0.066$   $\mu$ F  
                            $P = 72$  mW     $L_o = 0.5$  mH

**AT 421 (dust protected)** – see Label

Dust sediments should be limited or avoided completely. To avoid an unusual rise in temperature of the dust tight housing through excessive dust sediments on the upper side, larger dust sediments should be removed.

If the equipment has to be opened for maintenance or repair, appropriate measurements have to be taken to avoid that dust penetrates into the housing interior.

When decommissioning, precautions should be taken that parts which are necessary for the tightness of the housing (gaskets, plane faces, etc.) are not damaged, if their exchange is intended.

**Instruments which are identified with CE-identification according to PED 97/23/EC**

Use, installation, start-up and maintenance of the equipment are permissible only according to manufacturer's instructions (see PSS and MI). The safe operation requires a regular check of the equipment (see recurring checks).

Screws, nuts, bolts and other equipment parts may only be loosened, opened or removed, if the equipment is in a depressurized condition.

An exception herefrom is the access to the electrical wiring and the control elements.

**Restrictions through applicable basic atmospheric conditions**

The transducers may be mounted to vessels and tube systems on which potentially explosive gas/air or vapour/air mixtures occur, at pressures of 0.8 bar to 1.1 bar and mixture temperatures of  $-20^{\circ}\text{C}$  to  $+60^{\circ}\text{C}$  (potentially explosive atmosphere).

On vessels and tube systems with flammable gases and liquids, of which the pressures and temperatures are outside of the above mentioned ranges, the transducers may only be mounted if the flammable materials do not form potentially explosive mixtures.

For reasons of design a zone carry-over is securely eliminated.

**Permissible Pressure Temperature Range with Pressure Equipment**

Material	Pressure		°C	-60 to -10	-10 to +120	+200	+250	+300	+350	+400	Test Pressure
C 22.8 St 35.8	PN 16	DIN	bar	12	16	13	11	9	8		22.9
	cl150	ANSI	bar	14	16	14	12	10	8		29
	PN 40	DIN	bar	30	40	35	32	27	21		57.2
	cl 300	ANSI	bar	38	46	43	41	38	37		77
	PN 64	DIN	bar	48	64	50	45	39	30		91.5
	PN 100	DIN	bar	73	98	80	70	60	48		140.1
	cl 600	ANSI	bar	76	92	87	83	77	73		149
	PN 160	DIN	bar	120	160	130	112	96	90	76	228.8
	cl 900	ANSI	bar	114	139	131	123	116	110	90	224
	PN 250	DIN	bar	187	250	200	175	150	140	119	357.5
cl 1500	ANSI	bar	191	231	219	206	180	145	120	383	
Material	Pressure		°C	-196 to -10	-10 to +50	+100	+200	+300	+400		Test Pressure
1.4571 1.4404	PN 16	DIN	bar	16	16	16	12	9	7		22.9
	cl150	ANSI	bar	19	18	16	13	10	6		29
	PN 40	DIN	bar	40	40	35	32	28	25		57.2
	cl 300	ANSI	bar	49	49	42	35	31	27		75
	PN 64	DIN	bar	64	64	57	51	45	33		91.5
	PN 100	DIN	bar	100	100	95	80	70	64		143
	cl 600	ANSI	bar	99	99	84	71	63	58		149
	PN 160	DIN	bar	160	160	142	128	113	97		228.8
	cl 900	ANSI	bar	148	148	126	107	94	87		224
	PN 250	DIN	bar	250	250	230	200	177	162		357.5
cl 1500	ANSI	bar	248	248	211	178	158	145		373	
Material	Pressure		°C		-10 to +200	+300	+400	+450	+500		Test Pressure
1.5415 15 Mo 3 16 Mo 3	PN 16	DIN	bar		16	12	11	11	6		23.8
	cl150	ANSI	bar		14	10	6	4	2		30
	PN 40	DIN	bar		40	32	28	27	16		59.4
	cl 300	ANSI	bar		44	42	36	33	24		77
	PN 64	DIN	bar		63	50	44	43	25		93.5
	PN 100	DIN	bar		100	80	71	69	40		148.4
	cl 600	ANSI	bar		88	84	73	67	55		154
	PN 160	DIN	bar		160	128	113	110	64		237.5
	cl 900	ANSI	bar		132	126	109	101	72		230
	PN 250	DIN	bar		250	194	173	167	100		375
cl 1500	ANSI	bar		221	210	182	169	120		383	

## ***DECLARATION OF CONFORMITY***

### ***- according to Annex VII of the Pressure Equipment Directive 97/23/EC***

We herewith declare in sole responsibility, that the products:

**Buoyancy Transmitter**  
**Types: 144 LD, 244 LD, 167 LP and their accessories**

comply with the Pressure Equipment Directive 97/23/EC and the  
**AD 2000-Instructions, TRB**

Applied conformity assessment procedures:

**Module B and D**  
**EC-Type-Examination and Quality Assurance for Production**

For these products the following EC-Certificates are existing:

**P-DDB-MAN/02/05/17329989-513**  
**DGR-0036-QS-198-02**

The engaged Notified Body is:

**TÜV SÜD Industrieservice GmbH, Gottlieb-Daimler-Str. 7, D-70794 Filderstadt**

### ***- Directive 94/9/EC and Directive 2004/108/EC***

For all below mentioned products of our Transmitter Series, in compliance with EC Certificates of Conformity, issued by the

**Physikalisch Technische Bundesanstalt**  
**Bundesallee 100**  
**D-38166 Braunschweig**  
**as Notified Body No. 0102**

it is certified herewith that the products comply with the requirements established by the Directives for Alignment of the Legal Requirements of the Member States 94/9/EC dated 23 March 1994, relating to the design and construction of equipment and protective systems intended for use in potentially explosive atmospheres, and Directive 2004/108/EC for electromagnetic compliance.

The requirements for the electromagnetic compliance of the Directive 2004/108/EC dated 15. December 2004, are being fulfilled for all equipment components, in compliance with the following norms:

EN 55011      Group 1, Class B, date May 2000  
EN 61326      date March 2002

Several norms indexed in the appropriate EC type-examination certificate have been replaced by updated editions. We hereby certify the conformity of the products to the updated editions of these norms, as the modified specifications have no relevance to the products.

Product	Type	Approval	Test Certificate	Guideline 94/9/EU
141GP / 142AP	AI 416	II 1/2 G EEx ib/ia IIB T4...T6	PTB 01 ATEX 2044	EN 1127-1:1997 EN 50284:1999 EN 50014:1997 + A1 + A2 EN 50020:1994
	AD 402 + AD 931	II 2 G EEx d IIC T6...T4	PTB 02 ATEX 1025 X	EN 50014:1997 + A1 + A2 EN 50018:2000
143DP	AI 417	II 1/2 G EEx ib/ia IIC T4...T6	PTB 01 ATEX 2044	EN 1127-1:1997 EN 50284:1999 EN 50014:1997 + A1 + A2 EN 50020:1994
	AD 403 + AD 931	II 2 G EEx d IIC T6...T4	PTB 02 ATEX 1025 X	EN 50014:1997 + A1 + A2 EN 50018:2000
144FP	AI 418	II 1/2 G EEx ib/ia IIB T4...T6	PTB 01 ATEX 2044	EN 1127-1:1997 EN 50284:1999 EN 50014:1997 + A1 + A2 EN 50020:1994
	AD 404 + AD 931	II 2 G EEx d IIC T6...T4	PTB 02 ATEX 1025 X	EN 50014:1997 + A1 + A2 EN 50018:2000
144LVD	AI 419	II 1/2 G EEx ib/ia IIB T4...T6	PTB 01 ATEX 2044	EN 1127-1:1997 EN 50284:1999 EN 50014:1997 + A1 + A2 EN 50020:1994
	AD 406 + AD 931	II 2 G EEx d IIC T6...T4	PTB 02 ATEX 1025 X	EN 50014:1997 + A1 + A2 EN 50018:2000
144LD	AI 591	II 1/2 G EEx ib/ia IIB/IIC T4...T6	PTB 01 ATEX 2176	EN 1127-1:1997 EN 50284:1999 EN 50014:1997 + A1 + A2 EN 50020:1994
	AD 405 + AD 931	II 2 G EEx d IIC T6...T4	PTB 02 ATEX 1025 X	EN 50014:1997 + A1 + A2 EN 50018:2000
244LD	AI 432	II 1/2 G EEx ib/ia IIB/IIC T4...T6	PTB 01 ATEX 2177	EN 1127-1:1997 EN 50284:1999 EN 50014:1997 + A1 + A2 EN 50020:1994
	AD 432 + AD 931	II 1/2 G EEx d IIC T4...T6	PTB 02 ATEX 1142	EN 50014:1997 + A1 + A2 EN 50018:2000 EN 50284:1999
HART/ FoxCom	AI 408	II 2 G EEx ib/ia IIB/IIC T4	PTB 01 ATEX 2168	EN 50014:1997 + A1 + A2 EN 50020:1994
HART/ FoxCom	AID 421	II 2 G EEx ib/ia d IIB/IIC T6	PTB 0. ATEX ....	EN 50014:1997 + A1 + A2 EN 50018:2000 EN 50020:1994
Profibus-PA Foundation F	AI 428	II 2 G EEx ia IIB/IIC T4/T6	PTB 01 ATEX 2156	EN 50014:1997 + A1 + A2 EN 50020:1994
Dust protection	AT 421	II 1 D – IP66 – T 85 °C	DMT 0.ATEX ....	EN 50281-1-1:1999 EN 50281-1-2:1999

This Declaration of Conformity is valid for all versions which are included in the type designation and are manufactured according to the type conformity documentation.

Given by

**FOXBORO ECKARDT GmbH**  
Pragstraße 82  
D-70376 Stuttgart

**Managing Director**  
Karl Heinz Neher

Stuttgart, 19 November 2009

Subject to alterations – reprinting, copying and translation prohibited. Products and publications are normally quoted here without reference to existing patents, registered utility models or trademarks. The lack of any such reference does not justify the assumption that a product or symbol is free.

FOXBORO ECKARDT GmbH  
Postfach 50 03 47  
D-70333 Stuttgart  
Tel. # 49(0)711 502-0  
Fax # 49(0)711 502-597  
<http://www.foxboro-eckardt.com>

DOKT 556 778 021

