

## 244LVP Intelligent Buoyancy Transmitter for Liquid Level, Interface and Density

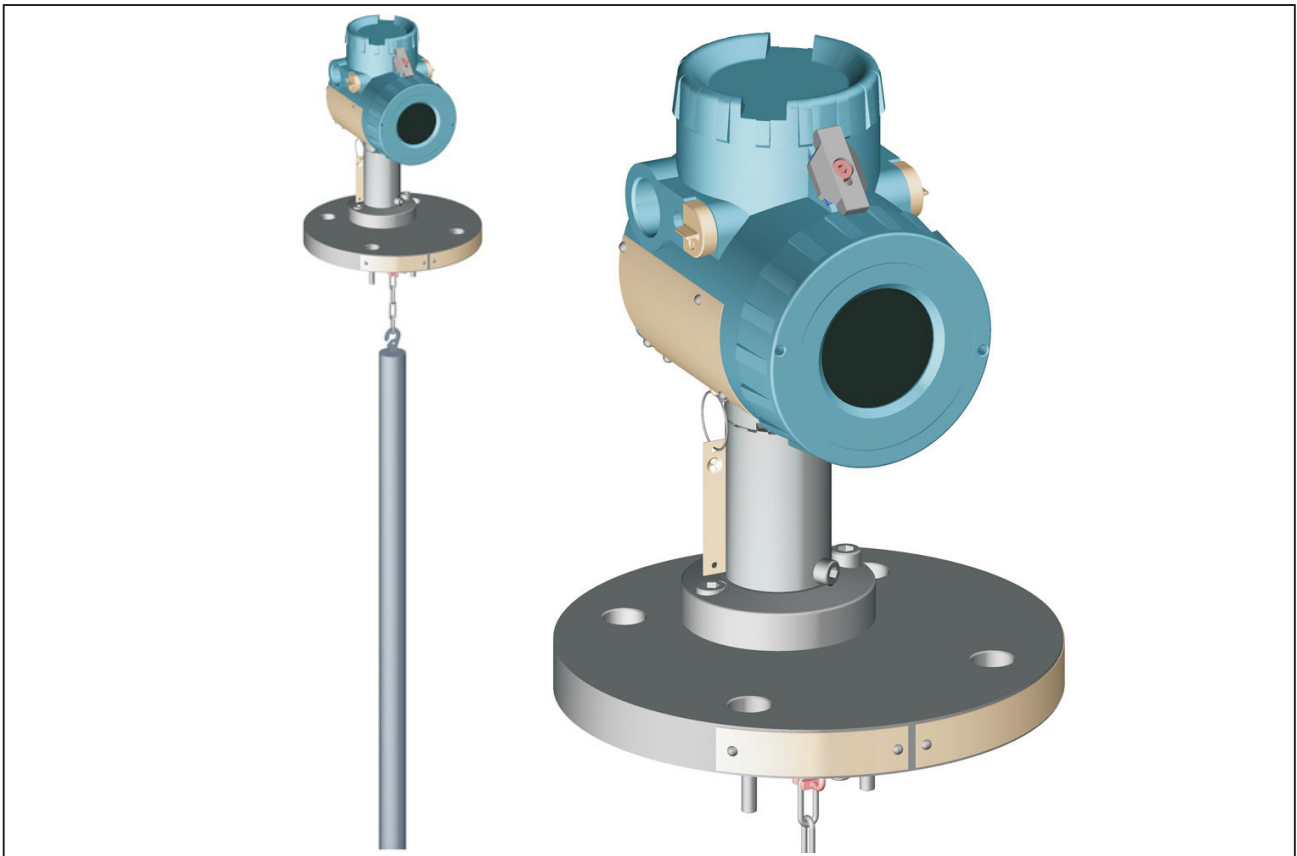

The intelligent transmitter 244LVP is designed to perform continuous measurements for liquid level, interface or density of liquids in the process of all industrial applications. The measurement is based on the proven Archimedes buoyancy principle and thus extremely robust and durable. Measuring values can be transferred analog and digital. Digital communication facilitates complete operation and configuration via PC or control system. The 244LVP measures with consistent reliability and high precision. For installations in contact with explosive atmospheres up to Zone 0, certificates are available. The 244LVP combines the abundant experience of FOXBORO ECKARDT with most advanced digital technology.

### FEATURES

- Communication HART (4-20 mA)
- Conventional operation with local keys
- Easy adaptation to the measuring point without calibration at the workshop
- Backdocumentation of measuring point
- Configurable safety value
- Software lock against unauthorized operation
- Simulation of analog output for loop-check
- Local display in %, mA or physical units
- Signal noise suppression by Smart Smoothing
- Continuous self-diagnostics
- Linear or customized characteristic
- Process temperature from  $-50\text{ }^{\circ}\text{C}$  to  $+150\text{ }^{\circ}\text{C}$
- Static pressure up to PN 40
- Micro sintermetal sensor technology

## TECHNICAL DATA

Data refer to the sensor material Type 316L (1.4404)

Explosion protection certificates must be observed!

### Input / Output

Measuring ranges . . . . . 0 ...50 mm to 0...3 m  
upper and lower range value  
continuously adjustable

Standard lengths of

Displacer (104DE) . . . . . 350 .. 3000 mm, 14 .. 120 in;  
further lengths on request

Weight of displacer <sup>1)</sup> . . . . . max. 25 N

Measuring span . . . . . 2... 20 N contin. adjustable  
(to 1 N on request)

Span ratio

Turn-down . . . . . 1:1 .. 1:10 (1:20 on request)

Accuracy <sup>2)</sup> . . . . .  $\pm 0.2\%$  ; increased accuracy  
with customized adjustment

Transfer function . . . . . linear or customized with up  
to 32 setpoints

Configuration

- with local push buttons and LCD
- Digital (see communication ...)

Local display . . . . . LCD 5 digits, configurable in  
%, mA or phys. units

Load . . . . .  $R_{Bmax} = (U_S - 12V) / 23\text{ mA}$

### Communication HART

Connection . . . . . Two-wire system

Supply voltage  $U_S$ : . . . . . 12 .. 42 V DC <sup>3)</sup>,  $V_{SS} < 1\%$

Current sink . . . . . max. 23 mA

Signal range . . . . . 4 .. 20 mA

Operating range . . . . . 3.8 .. 21 mA

Digital communication . . . . . HART Protocol, 1200 Baud

Hand held terminal . . . . . HHT 991

PC Software . . . . . PC20 / PC 50

Hardware . . . . . HART Modem MOD991 for PC

Min. load . . . . . 250  $\Omega$

### Failure handling

Substitute value. . . . . last value or safety value

Safety value . . . . . 3.6 ... 23 mA, adjustable

Reset substitute value . . . . . automatically or manual

Select messages. . . . . Internal calibration failed,

Pressure peaks > 150 %,

Data access failed,

Over range > 110 %,

Ambient temp. out of limits,

Process temp. out of limits,

Measuring range invalid

1) For measurement of interface or density:  
25 N + buoyant force at lowest density

2) Acc. ANSI / ISA - S51.1 - 1979

3) With explosionproof device 12 .. 30 V

**Operating conditions** <sup>1)</sup>

Process temperature . . . . . -50 °C ... +150 °C  
 Pressure rating  
 acc. to DIN . . . . . PN 40  
 acc. to ANSI . . . . . Class 150, 300  
 Ambient temperature <sup>2)</sup>  
 without indicator . . . . . -40 °C ... +85 °C  
 with LCD indicator . . . . . -40 °C ... +70 °C <sup>3)</sup>  
 Relative humidity . . . . . < 100%  
 Condensation . . . . . permitted  
 Transportation-  
 storage temperature . . . . . -50 °C ... +85 °C  
 Protection . . . . . IP 66 (acc. DIN EN 60 529)

**Operation condition effects**

Ambient temperature . . . . . -10 °C ... +70 °C  
 Zero . . . . . < 0.1 % / 10 K <sup>4)</sup>  
 Span . . . . . < 0.07 % / 10 K  
 Total  

$$\left(0.1 \frac{\text{max. sp.}}{\text{adjusted sp.}} \pm 0.07 \frac{\text{measured value}}{\text{adjusted sp.}}\right) \% / 10\text{K}$$
 (*sp.* = measuring span)  
 < -10 °C / > +70 °C . . . . . twice the value  
 Process temperature . . . . . < 0.1 % / 10 K <sup>4)</sup>  
 Operating pressure . . . . . < 0.03 % / 10 bar

**Transitional behavior**

Dynamic behavior  
 Damping (90%-time) . . . . . 0 ... 32 s  
 Switch-on time . . . . . 7 s  
 Step response (63%-time)  
 with damping 0 s . . . . . 250 ms  
 Update rate . . . . . 10/s  
 Long term stability . . . . . < 0.2 % / 6 months at 20°C <sup>4)</sup>  
 Noise suppression  
 Common mode voltage . . . . . < AC 250 V<sub>eff</sub>  
 Common mode rejection . . . . . 120 dB  
 Series mode rejection . . . . . 50 dB  
 Mains synchronization . . . . . 50 Hz / 60 Hz  
 Filter . . . . . Smart Smoothing

1) Not with all materials - see Table of Comparison of Materials page 6

2) -50 °C on request

3) Display invisible at temperatures less than -30 °C

4) For max. measuring span

**Materials** (Table of Comparison see page 6)

Sensor	
Measuring cell	316L (1.4404 / 1.4435) or Hastelloy C
Fill fluid	silicone oil
Filling volume	approx. 0.3 cm <sup>3</sup>
Displacer 104DE	316L (1.4404 / 1.4435), PTFE, PTFE with 25% carbon or Hastelloy C
Suspension	316L (1.4404 / 1.4435 / 1.4436) or Hastelloy C
Connection flange	316 (1.4404 / 1.4571)
Amplifier housing	Aluminium (Alloy No GD-Al Si 12), Polyurethan coated, or Stainless Steel 316L (1.4404)
For Sour Gas applications according to NACE Standard MR-0175-95:	
Diaphragm	Hastelloy C
Flange	316 (1.4404 / 1.4571)

**Mounting**

Mounting method	flange mounted
acc. DIN	DN 50, DN 80
acc. ANSI	2 inch or 3 inch

**Weight**

Transmitter	see table page 6
Displacer	see table page 10

**Electrical connection**

Cable entry thread	M20x1.5 or 1/2-14 NPT
Cable gland and screwed sealing plug	have to be ordered separately under model code BUSG ...
For equipment in Ex d version,	1 screwed sealing plug made of stainless steel is included in delivery.
Screw terminals	wire cross-section up to 2.5 mm <sup>2</sup>
Test sockets	Ø 2 mm

**Electromagnetic compatibility EMC**

Operating conditions	industrial environment
Immunity according to EN 61326 (3/2002)	fulfilled
Emission according to EN 61326 (3/2002)	fulfilled
EN 55011, May 2000, Group 1, Class A	fulfilled
EN 61000-6-3	fulfilled
NAMUR recommendation Ne21 Status Aug.1998	fulfilled

**SAFETY REQUIREMENTS****CE Label**

Electromagnetic compatibility	89/336/EWG
Low-voltage regulation	73/23/EWG
Explosion protection	94/9/EG

**Safety**

According to EN 61010-1 (resp. IEC 1010-1)	safety class III
Internal fuses	none (or not replaceable by customer)
External fuses	Limitation of power supplies for fire protection have to be observed due to EN 61010-1, appendix F (rsp. IEC 1010-1)

**Electrical classification ATEX** <sup>1) 2)</sup>**Intrinsic safe:**

AI 408	HART electronics	II 2 G EEx ia/ib IIB/IIC T4	PTB 01 ATEX 2168	Zone 1
mounted with:				
AI 419 C	Sensor part 244LVP	II 1/2 G EEx ib/ia IIB T4..T6	PTB 01 ATEX 2044	Zone 0
AI 419 D	Sensor part 244LVP	II 1/2 G EEx ib/ia IIC T4..T6	PTB 01 ATEX 2044	Zone 0

**Explosion-proof:**

AD 931	Housing for HART	II 2 G EEx d IIC T6	PTB 02 ATEX 1025 X	Zone 1
mounted with:				
AD 406 D	Sensor part 244LVP	II 2 G EEx d IIC T6..T4	PTB 02 ATEX 1025 X	Zone 1
AD 406 C	Sensor part 244LVP	II 2 G EEx d IIB T6..T4	PTB 02 ATEX 1025 X	Zone 1

**Intrinsic safe and auxiliary protection:**

AID421	Housing for HART <sup>1)</sup>	II 2 G EEx ia d IIC T6	PTB 04 ATEX 2011 X	Zone 1
mounted with:				
AD 406 D	Sensor part 244LVP	II 2 G EEx d IIC T6..T4	PTB 02 ATEX 1025 X	Zone 1
AD 406 C	Sensor part 244LVP	II 2 G EEx d IIB T6..T4	PTB 02 ATEX 1025 X	Zone 1

**Zone 2:**

AN 408	HART electronics	II 3 G EEx ia/ib IIC T4	Certificated by Manufacturer	Zone 2
mounted with:				
AI 419 C	Sensor part 244LVP	II 3 G EEx ib/ia IIB T4..T6	PTB 01 ATEX 2044	Zone 2

**Further National certificates****- Overfill protection according to WHG****International Certificates****FM Certification**

Intrinsically Safe / I, II, III / 1 / ABCDEFG / T4 Ta=85°C

Nonincendive / I / 2 / ABCD / T4 Ta=85°C

Special Protection / II / 2 / FG / T4 Ta=85°C

Special Protection / III / 2 / T4 Ta=85°C

Explosion proof / I / 1 / BCD / T6

Dust-Ignitionproof / II, III / 1 / EFG / T6

Type 4X

Entity Parameters:

V<sub>max</sub>=30 V, I<sub>max</sub>=150 mA, C<sub>i</sub>=2.45 nF, L<sub>i</sub>=0.14 mH**CSA Certification**

Intrinsically safe / I, II, III / 2 / ABCDEFG /

T3C Ta= 85 °C

T4 Ta= 60 °C

T4A Ta= 40 °C

Type 4X

Explosionproof / I, II, III / 1 / CDEFG / Ta= 85 °C

Type 4X

**RUSSIAN “Intrinsic safety”****RUSSIAN “Explosionproof”****Belarus - Certificate Number 2176**

- Further protection types of on request -

1) With appropriate order only

2) National requirements have to be observed

## TABLE OF MATERIALS

### Comparison of Material

Code	WNr	DIN	Remarks	equivalent to
X6 CrNiMoTi 17 12 2	1.4571	17 440		~ ASTM Typ 316Ti
X2 CrNiMo 17 13 2	1.4404			ASTM Typ 316L
X2 CrNiMo 18 14 3	1.4435			
X5 CrNiMo 17 13 3	1.4436			
NiMo 16 Cr 15 W	2.4819	17 744	equivalent to Hastelloy C-276 VdTÜV - Wbl. 400	UNS N 12 276
GD - AlSi 12	3.2582.05	17 007	Al - Diecasting	

### Service Limits 244LVP

Nominal pressure	316 / 316L (1.4404 / 1.4571) Hastelloy C		
	Max. operating pressure in bar at temperature in °C		
	-50 ... -10	-10 ... +50	+150
PN 40 DIN 2635	40	40	34
Class 150	19	18	15
Class 300	49	49	40

### Table of Weights

Transmitter, without displacer	Weight [ kg ]		
	PN	Class	
	40	150	300
DN 50 / 2 inch	4.9	4.5	5.5
DN 80 / 3 inch	7.2	7.4	9.2

## CONNECTIONS, OPERATIONAL ELEMENTS

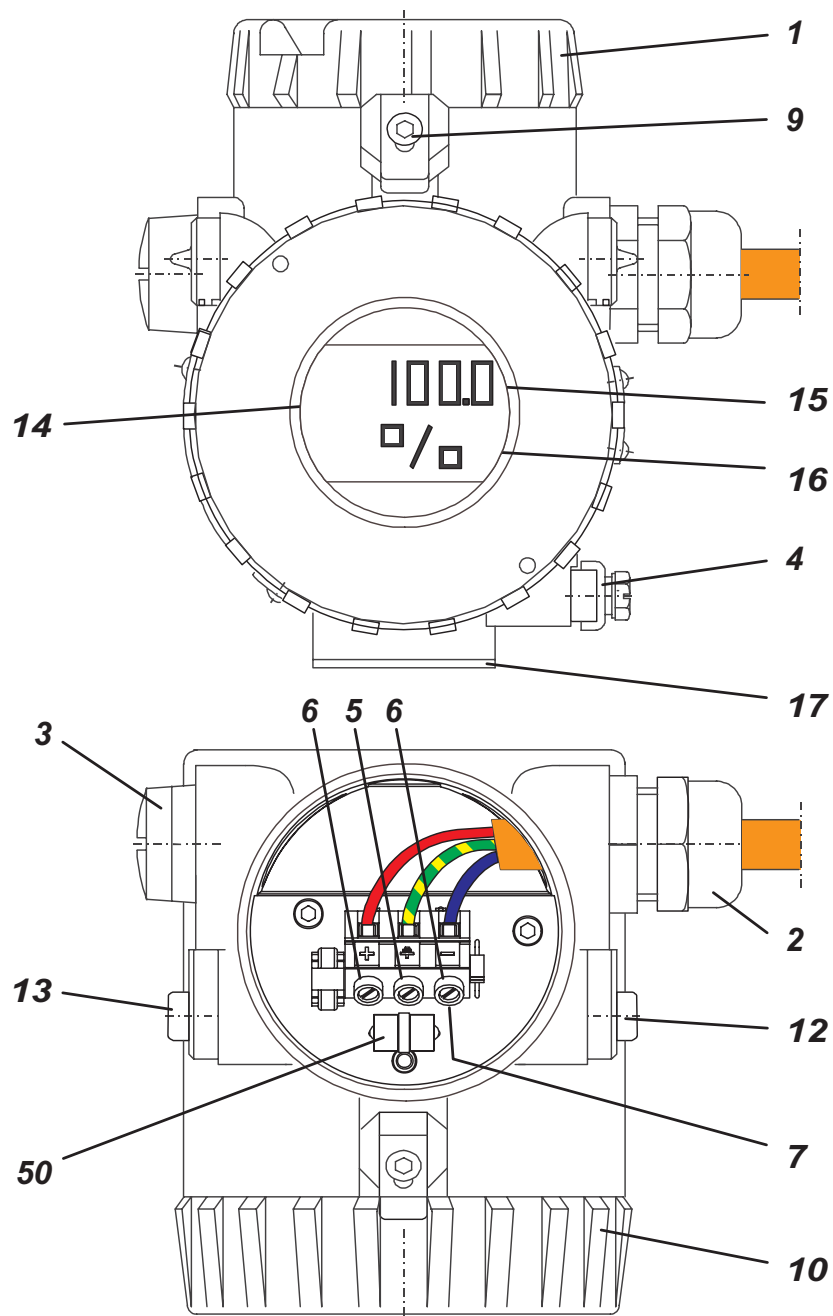

**1** Cover for terminal compartment

**2** Cable gland (as ordered)

**3** Plug, interchangeable by Pos. **2**

**4** External ground connection

**5** Internal ground connection

**6** Terminals (+/-)

**7** Test sockets Ø 2 mm integrated in terminals

**9** Security lock for EEx d version

**10** Cover for amplifier housing (with local display)

**12** Local key for lower range value / zero

**13** Local key for upper range value / damping

**14** LCD indicator

**15** Measuring variable

**16** Engineering unit

**17** Bottom housing cover

**50** Overvoltage protection (if present)

**MODEL CODES 244LVP**

<b>Intelligent Buoyancy Transmitter with Displacer</b>	<b>244LVP</b>								010209
<b>Flange Material: (Process wettet)</b>									
1.4571 (316Ti)									-S
Titan 3.7025 / 3.7035		(h)							-T
<b>Sensor Material: (Process Wetted)</b>									
316L / 1.4435 / 1.4404									S
316L / 1.4435 / 1.4404 with HC-Diaphragm									N
Titan 3.7025 / 3.7035		(h)							T
<b>Flange Size</b>									
DN 50									5
DN 80									8
2-Inch									2
3-Inch									3
<b>Flange Pressure Rating &amp; Contact Face</b>									
PN 16 to PN 40, C (DIN 2526)		(a)							C1
PN 16 to PN 40, E (DIN 2526)		(a)							E1
PN 16 to PN 40, N (DIN 2512)		(a)							N1
PN 16 to PN 40, B1 (DIN EN 1092-1)		(a)							B1
PN 16 to PN 40, B2 (DIN EN 1092-1)		(a)							B2
PN 16 to PN 40, D (DIN EN 1092-1)		(a)							D1
ANSI Class 150, RF RF/SF (RF125)		(b)							R1
ANSI Class 300, RF RF/SF (RF125)		(c)							R2
ANSI Class 150, RJF		(b)(g)							J1
ANSI Class 300, RJF		(c)(g)							J2
<b>Version</b>									
Base									B
<b>Cable Entry</b>									
M20x1.5 without Cable Gland									M
1/2-14 NPT without Cable Gland									N
<b>Communication</b>									
HART									H
<b>Electrical Classification</b>									
ATEX intrinsic safe, Zone 0 - IIB T4		(d)							0B4
ATEX Intrinsic safe, Zone 0 - IIC T4									0C4
ATEX intrinsic safe, Zone 1 - IIC T4									1C4
ATEX intrinsic safe, Zone 1 - IIC T6									1C6
ATEX intrinsic safe, Zone 2 - IIC T4									2C4
ATEX intrinsic safe, Zone 2 - IIB T6									1B6
ATEX intrinsic safe, Zone 1 - IIB T6									D1B
ATEX explosionproof, Zone 1 - IIC T6									D1C
FM Nonincendive									NFM
FM Explosionproof		(d)							FDZ
RUS Intrinsically Safe		(d)							GAA
CSA Explosionproof		(d)							CDZ
FM Intrinsically Safe									FAA
CSA Intrinsically Safe		(d)							CAA
For General Purpose Areas, not Explosionproof									ZZZ
<b>OPTIONS</b>									
(continued on next page)									

**MODEL CODES 244LVP (continued)**

**Options**

**Tag No. Labeling**

Stainless Steel Label Fixed With Wire . . . . .	-L
Stainless Steel Label Fixed On Amplifier . . . . .	-F

**National Certificates**

Overfill Protection Per WHG Environmental Pollution . (d). . . . .	-V
--	----

**Certificates**

EN 10204-2.1, Certificate Of Compliance . . . . .	-1
EN 10204-2.2, Specific Test Report (Calibration) . . . . .	-2
EN 10204-3.1, Inspection Certificate Of Process Wetted Metallic Material. . . . .	-3
Comply with NACE Standard MR-01-75 (e)(f) . . . . .	-6
EN 10204-3.1, Inspection Certificate of Process wetted Material with Copy of Original individual Material certificate . . . . .	-9

- (a) Available with Flange Size 5 or 8
- (b) Available with Flange Size 2 or 3
- (c) Available with Flange Size 3
- (d) Pending
- (e) Only with Sensor Material N
- (f) Restrictions concerning the limit of application for the used materials are considerable (NACE Standard MR-0175/2003, resp. ISO 15156-3)
- (g) Not with Electrical Classification 0B4 and 0C4
- (h) On request

## Displacer 204DE

### Typical Dimensions and Weights for Density Ranges $\Delta\rho$ <sup>1)</sup>

Material	316L (1.4404 / 1.4435) <sup>2)</sup>										PTFE / PTFE with 25 % C				Hastelloy C									
Code	-S (PN 100)				-T <sup>3)</sup> (PN 40 / 63)				-S (PN 250)				-S (PN 500)				-S (PN 100 / 160)							
Len. L	Density Range $\Delta\rho$																							
	250 ... 1500 kg/m <sup>3</sup>					100 ... 600 kg/m <sup>3</sup>					400 ... 2000 kg/m <sup>3</sup>					200 ... 1500 kg/m <sup>3</sup>					300 ... 1500 kg/m <sup>3</sup>			
mm	$\varnothing$ mm	Vol. cm <sup>3</sup>	Wei. N	PN bar	$\varnothing$ mm	Vol. cm <sup>3</sup>	Wei. N	PN bar	$\rho_{min}$ <sup>4)</sup> kg/m <sup>3</sup>	$\varnothing$ mm	Vol. cm <sup>3</sup>	Wei. N	PN bar	$\varnothing$ mm	Vol. cm <sup>3</sup>	Wei. N	PN bar	$\varnothing$ mm	Vol. cm <sup>3</sup>	Wei. N	PN bar			
350	60.3	1000	19	100	101.6	2840	38	40	460	42.4	500	18	250	62	1056	23	500	60.3	1000	18	100			
500	48.3	920	17	100	88.9	3100	43	63	580	42.4	710	24	250	51	1021	23	500	48.3	920	19	100			
750	42.4	1060	21	100	76.1	3410	44	63	545	33.7	670	21	250	42	1039	24	500	48.3	1370	27	100			
1000	33.7	890	17	100	60.3	2855	41	63	545	26.9	570	18	250	35	961	21	500	33.7	890	19	100			
1200	33.7	1070	20	100	60.3	3425	48	63	675	26.9	680	22	250	35	1153	25	500	33.7	1070	22	100			
1500	26.9	850	16	100	51	3065	39	63	460	21.3	540	17	250	30	1060	24	500	26.9	850	18	160			
1800	26.9	1020	19	100	42.4	2540	38	63	495	21.3	640	20	250	28	1107	25	500	26.9	1020	21	160			
2000	26.9	1140	21	100	42.4	2825	41	63	565	21.3	710	22	250	25	981	22	500	26.9	1140	23	160			
2500	21.3	890	20	100	38	2840	37	63	425	17.2	580	16	250	22.5	993	23	500	21.3	890	23	160			
3000	21.3	1070	24	100	38	3400	45	63	575	17.2	700	23	250	20	942	22	500	21.3	1070	27	160			
inch																								
14	60.3	1020	20	100	101.6	2885	38	40	455	42.4	510	18	250	62	1074	23	500	60.3	1020	18	100			
32	42.4	1150	23	100	76.1	3700	47	63	595	33.7	730	23	250	42	1126	26	500	33.7	720	16	100			
48	33.7	1090	20	100	60.3	3480	49	63	680	26.9	690	22	250	35	1171	26	500	33.7	1090	23	100			
60	26.9	870	16	100	51	3115	40	63	465	21.3	540	18	250	30	1076	24	500	26.9	870	18	100			
72	26.9	1040	19	100	42.4	2580	38	63	505	21.3	650	21	250	28	1124	26	500	26.9	1040	21	160			
84	26.9	1210	22	100	42.4	3000	44	63	635	21.3	760	23	250	25	1046	24	500	26.9	1210	25	160			
96	21.3	870	20	100	38	2765	37	63	420	17.2	570	16	250	22.5	968	22	500	21.3	870	23	160			
120	21.3	1090	25	100	38	3455	46	63	595	17.2	710	24	250	20	957	22	500	21.3	1090	25	160			

- $\Delta\rho = \rho_1 - \rho_2$   
 $\rho_1$  = density of lower medium  
 $\rho_2$  = density of upper medium
- Using displacer material 1.4571 can cause small deviations in diameter, volume and weight.
- For measurement of interface or density, the max. density of the lower medium is 1350 kg/m<sup>3</sup>.
- Min. density of the lower medium

If a Displacer Chamber is used, the difference between the diameter of the Displacer and the inside diameter of the Displacer Chamber must be at least 10 mm.

Lengths < 350 mm and > 3000 mm, and density ranges < 100 kg/m<sup>3</sup> and > 2000 kg/m<sup>3</sup> on request.

### Accessories

For Displacer Chamber 204DC, Flange combination 204FK and Cover Flange Kit 204BCF see PSS EML0901, 204.. Accessories for Buoyancy Transmitter.

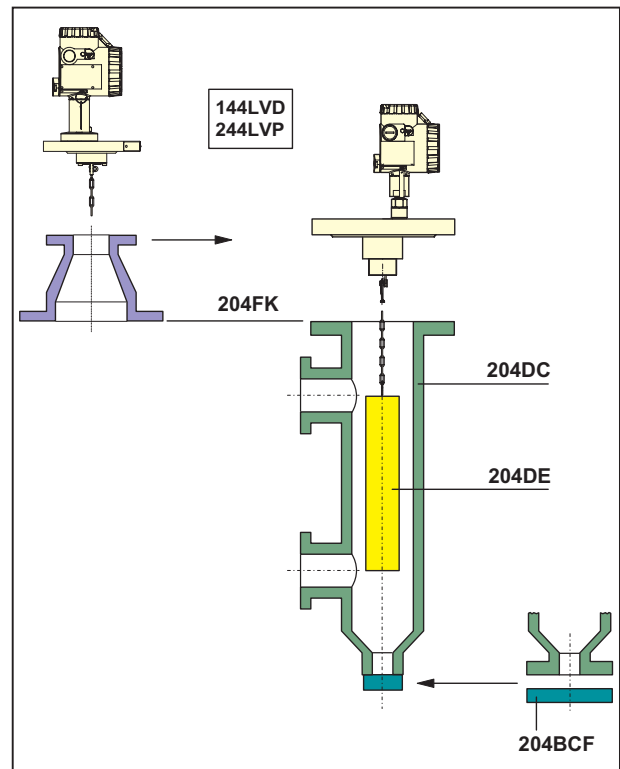



**MODEL CODES 204DE**

<b>Displacer for Buoyancy from 2 N to 20 N</b>	<b>204DE</b>	010808
<b>OPTIONS</b>		
For application in Zone 0 (Additional grounding rope) (not available with Displacer Material: P)		-E
Damping Spring (Mat. 1.4310, max. 250°C (482F)) . . . (f)		-D
Damping Spring (Mat. HC, max. 350°C (662F)) . . . (f)		-C
Degreased . . . . .		-O
<b>Tag No. Labeling</b>		
Stainless Steel Label Fixed With Wire (Text required)		-L
<b>Certificates</b>		
EN 10204-2.1 Certificate Of Compliance . . . . .		-1
EN 10204-3.1 Inspection Certificate Of Process Wetted Material (not available with Displacer Material: P and O)		-3
PMI - Test (not available with Displacer Material: P and O)		-5

- (a) Upper and Lower Medium Density required (at operating temperature)
- (b) Only in connection with Modelcode 204DC
- (c) Exact length required (Contact face of flange to upper end of displacer)
- (d) All +/- 8mm (0.3 inch)
- (e) Pending
- (f) Required for 244LD Option -G

**DIMENSIONS**

DN 50 and DN 80

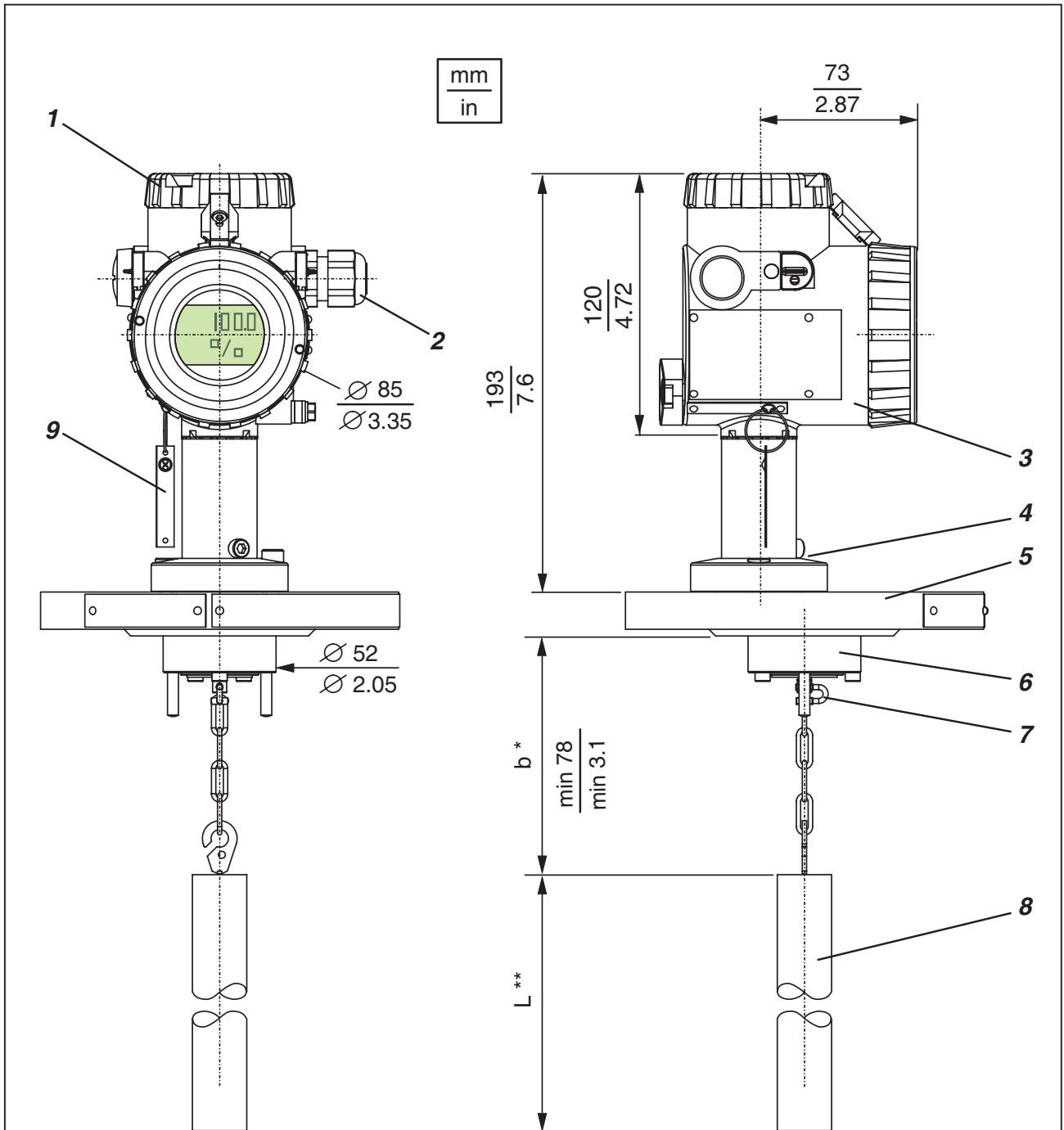

- 1 Connecting compartment cover
- 2 Cable entry with screwed gland
- 3 Amplifier housing
- 4 Disconnection of sensor from the amplifier
- 5 Connection flange (as per DIN / ANSI)
- 6 Measuring cell
- 7 Suspension
- 8 Displacer 104DE
- 9 Steel label with Tag.No.

\* Suited to the dimensions of  
FOXBORO ECKARDT - displacer,  
other lengths on request

\*\* L (measuring range) see table page 10.

**Product Specifications for Intelligent Transmitters**

PSS EMP0610 A-(en)	141GP	Intelligent Gauge Pressure Transmitter<R>
PSS EMP0620 A-(en)	142AP	Intelligent Absolute Pressure Transmitter
PSS EMP0630 A-(en)	143DP	Intelligent d/p Transmitter
PSS EML0610 A-(en)	144LD	Intelligent Buoyancy Transmitter with Torque Tube for Liquid Level, Interface and Density
PSS EML0710 A-(en)	244LD	Intelligent Buoyancy Transmitter with Torque Tube for Liquid Level, Interface and Density
PSS EML1610 A-(en)	144LVD	Intelligent Buoyancy Transmitter for Liquid Level, Interface and Density
PSS EML1710 A-(en)	244LVP	Intelligent Buoyancy Transmitter for Liquid Level, Interface and Density
PSS EML2610 A-(en)	144FP	Intelligent d/p Transmitter for Liquid Level, Interface and Density - Flange mounted
PSS EML0900 A-(en)	104..	Accessories for Buoyancy Transmitters
PSS EMO0100 A-(en)		Accessories for Devices with HART-Protocol

Subject to alterations - reprinting, copying and translation prohibited. Products and publications are normally quoted here without reference to existing patents, registered utility models or trademarks. The lack of any such reference does not justify the assumption that a product or symbol is free.

FOXBORO ECKARDT GmbH  
Postfach 50 03 47  
D-70333 Stuttgart  
Tel. # 49(0)711 502-0  
Fax # 49(0)711 502-597  
<http://www.foxboro-eckardt.com>

DOKT 556 882 022