

## GAE953 Electrical Alarm Unit 19" with Indicator



The electrical alarm unit GAE953 gives a signal when one or two set alarm values have been exceeded. Input signals from 0/4 to 20 mA, from 0 to 10 V, from 1 to 5 V, from 0/0.2 to 1 V can be processed as input variables. The device has two inputs with min. (= low) or max. (= high) monitoring, but they can also be switched together for min. and max. monitoring of a single input or of a difference between 2 inputs. The digital display at the front plate permits the control of the inputs as well as the set alarm values.

### FEATURES

- Use as
  - double alarm unit for 1 input signal or as
  - double alarm unit for differential signal between 2 inputs or as
  - 2 single alarm units for 2 separate inputs
- 3 1/2 position LED digital display at front plate to indicate input and alarm values
- Input or alarm value display from channels 1 and 2
- Minimum or maximum value monitoring can be selected
- Normally closed or normally open circuit can be selected
- Alarm value setting by means of a potentiometer at front plate
- Alarm indication by means of red LEDs
- Alarm monitoring by means of relay outputs with double contacts
- Line break detection
- Galvanic separation between input, power supply and output
- EMC in accordance with the latest NAMUR-recommendations and international standards and laws

**TECHNICAL DATA****Operating mode**

Min. (= low)/max. (= high) and normally closed/normally open<sup>1)</sup> selection via jumpers

**Input**

Inputs ..... 1 or 2 (galvanically connected)  
 Differential input ..... selectable  
 Difference forming<sup>2)</sup> .....  $0.5(E2-E1)+50\%$   
 Line break detection ..... disconnectible  
 Sensitivity .....  $\leq 0.2$  mA  
 Number of alarm values ..... 2<sup>3)</sup>

**Input signal**

Current ..... 0/4 to 20 mA  
 Input resistance ..... 50 Ohm  
 Voltage ..... 0 to 10 V/1 to 5 V/  
 0 to 1 V/0.2 to 1 V  
 Input resistance .....  $>250$  kOhm

**Display**

Input or alarm value ..... 3 1/2 position, consists of 7-segment LED, 3-digit digit-height 5 mm and 2 LEDs (green)<sup>4)</sup>  
 Scaling ..... in %  
 Input or alarm value ..... selection via switch

Alarm value exceed indication ..... LED (red) lights up  
 Line break indication ..... LED (red) lights up<sup>5)</sup>

**Output**

Alarm value monitoring ..... 2 relays each with 2 isolated changeover contacts  
 Line break monitoring<sup>5)</sup> ..... relay with isolated changeover contact

**Relay data**

Switching capacity ..... max. 30 W  
 Switching voltage ..... max. 30 V  
 Switching current ..... max. 1 A  
 Response time ..... approx. 25 ms  
 OFF delay in the event of mains interruption ..... approx. 25 ms

**Response characteristics**

Alarm values ..... 0 to 100%, continuously adjustable  
 Hysteresis ..... 1% F.S., optionally 2, 5, 10% F.S.  
 Accuracy .....  $\leq 0.5\%$  F.S.  
 Reproducibility at 20°C and nominal voltage .....  $\leq 0.5\%$  F.S.  
 Alarm value change resulting from power supply change in entire tolerance range .....  $\leq 0.2\%$  F.S.  
 resulting from temperature change per 10 K. .....  $\leq 0.1\%$  F.S.

**Galvanic separation** ..... between input, power and output

**Electromagnetic compatibility EMC**

Immunity as per EN 50 082-2 ..... fulfilled  
 Emission as per EN 50 081-2 ..... fulfilled  
 Operating conditions ..... industrial environment  
 NAMUR-recommendation ..... fulfilled

**Power supply**

AC voltage ..... AC 24 V  
 Tolerance ..... +15%, -20%  
 Nominal frequency range ..... 50 to 60 Hz  
 Tolerance .....  $\pm 2$  Hz  
 Power consumption .....  $<3$  VA  
 DC voltage ..... DC 24 V  
 Tolerance ..... +30%, -25%  
 Residual ripple .....  $<15\%$  within the tolerance range  
 Power consumption .....  $<3$  W  
 Start up current .....  $<15 \times I_{nom}$   
 Operating conditions as per IEC 654-2 ..... The device can be operated on a class a.c.4 or d.c.4 power supply

**Ambient conditions**

Ambient temperature (Device) ..... 0°C to +60°C  
 Relative humidity ..... 10 to 75%  
 Condensation ..... none  
 Operating conditions as per IEC 654-1 ..... The device can be operated at a class B2 location  
 Transport- and storage temperature ..... -25°C to +70°C

**Design**

19"-device (nest mounted) ..... Euro format 100 x 160 mm  
 Front ..... 4 TE, 3 HE, Color RAL 7032  
 Connector ..... male multipoint DIN 41 612 type F, 32 poles, series z and d  
 Weight ..... approx. 0.25 kg

**Safety requirements**

as per IEC 1010-1 ..... protection class III  
 Built-in fuse ..... DIN 41 571 - T0,2A

- 1) Normally closed: relay coil energized within the positive range/ normally open: relay coil not energized within the positive range
- 2) For input with life zero (e.g. 4 to 20 mA) only
- 3) 1 alarm value per input with 2 input signals (G1/E1 resp. G2/E2), 2 alarm values with single input signal or with differential input
- 4) For indicating values  $\geq 100\%$  resp.  $<0\%$
- 5) If line break detection is connected

**MODEL CODE**

<b>GAE953 Alarm Unit with Indicator</b>	
<b>Version</b>	
-M	Nest-Mounted Module with relay for line break detection for signal range 4-20 mA, 1-5 V, 0.2-1 V
<b>Input</b>	
1	0 to 20 mA
2	4 to 20 mA
3	0 to 10 V
4	1 to 5 V
5	0 to 1 V
6	0.2 to 1 V
<b>Number of Input Signals</b>	
1	1 Input E1
2	2 Inputs E1 and E2
3	Differential input E2–E1 (for input with code 2, 4, 6 only)
<b>Relay Action for all Outputs</b>	
A	Normally closed (Circuit opens on alarm)
B	Normally open (Circuit closes on alarm)
<b>Alarm Configurations</b>	
1	Alarm G1 low/G2 high
2	Alarm G1 low/G2 low
3	Alarm G1 high/G2 high
4	Alarm G1 high/G2 low
<b>Electrical Classification</b>	
ZZZ No Certification/approval	
<b>Optional Features</b>	
-N	Nameplate Inscription (b)
-Q	Hysteresis 2% (Standard = 1%)
-R	Hysteresis 5% (Standard = 1%)
-S	Hysteresis 10% (Standard = 1%)
<b>Accessory Connector with</b>	
-1	Solder connections (a)
-2	Wire wrap connections (a)
-3	Screw terminals (a)
-4	Crimping connections (a)
-5	Au clip pin 0.8 x 1.6 connection (a)
-6	Sn clip pin 0.8 x 1.6 connection (a)
-7	Au clip pin 0.8 x 2.4 connection (a)
-8	Sn clip pin 0.8 x 2.4 connection (a)
-9	Flat push on connections 2.8 x 0.8 (a)
↓	↓
↓	↓
↓	↓
↓	↓
↓	↓
↓	↓
↓	↓
GAE953	
Example Model Code:	
GAE953-M 2 1 A 1 ZZZ -N1	
(a)	Female multipoint connector DIN 41 612 type F, 32 poles, series z and d, for external mounting
(b)	Location label with inscription: max. 6 characters per line, max. 3 lines in font IBM Courier 12 or max. 6 characters per line, max. 2 lines in font IBM Orator 10

**Data Sheets 19"-Racks, Single Housings, Field Housings**

7 118 100	FG 118	Field housing for 19"-moduls
7 119 100	WG 119	Single housing for 19"-moduls
7 123 100/200	BGT 123	19"-Rack unit with female multipoint connectors/ ...with front connections
7 124 000	BGT 124	19"-Rack unit with backside terminal board
7 124 160	BGT 124N	19"-Rack unit with backside terminal board and with power supply unit

## CONNECTION DIAGRAM

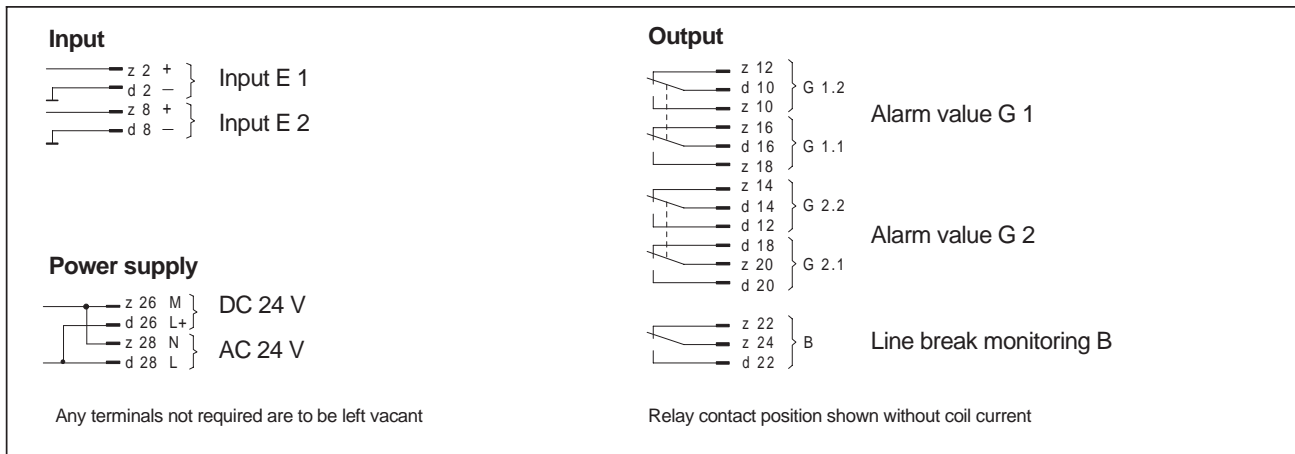

## DIMENSIONS

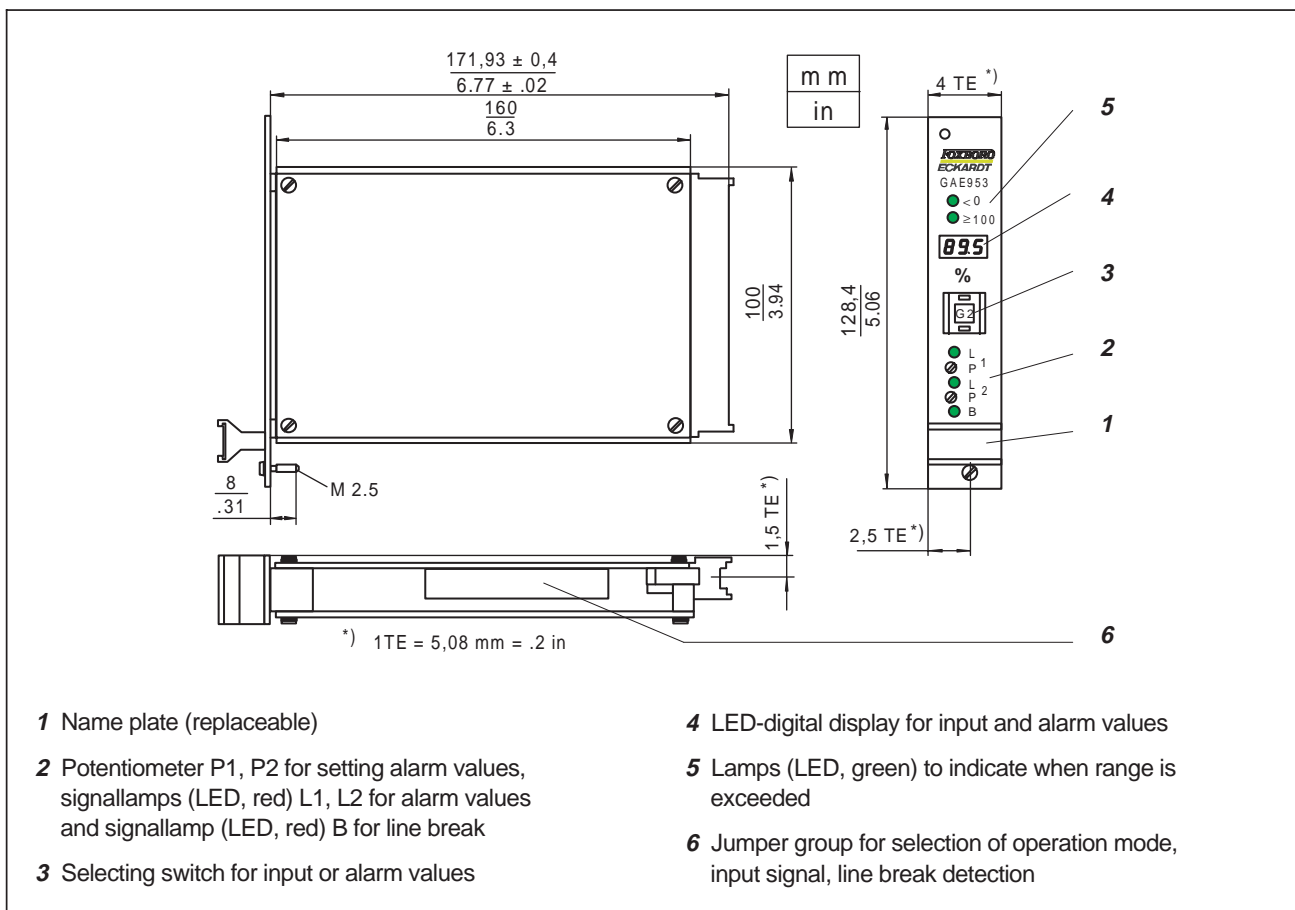

Subject to alterations - reprinting, copying and translation prohibited. Products and publications are normally quoted here without reference to existing patents, registered utility models or trademarks. The lack of any such reference does not justify the assumption that a product or symbol is free.

FOXBORO ECKARDT GmbH  
 Postfach 50 03 47  
 D-70333 Stuttgart  
 Tel. # 49(0)711 502-0  
 Fax # 49(0)711 502-597

