

MUS924 Power Supply Unit / Buffer Amplifier 19"



The Power Supply Unit MUS924 is a component of the FOXBORO ECKARDT 19" system which can be used either as a transmitter power supply unit or as a buffer amplifier. As a power supply unit the device supplies electronic transmitters in "2-wire design". Noise-free signal transmission is guaranteed by the galvanic separation of the circuit. As a buffer amplifier the device separates signal circuits galvanically and prevents undesirable intermeshing and disturbances as the load is increased.

FEATURES

- Pin assignment determines power supply unit or buffer amplifier
- Linear / square-root-extraction versions
- Switchable signal range
- Version with voltage output
- Intrinsically safe [EEx ib]
- Galvanic separation between input or transmitter power supply circuit, output and power supply
- EMC in accordance with international standards and laws (CE)
- Power supply AC / DC 24 V
- Low power loss
- Device width 4 TE
- Operation indicated by LED
- Sockets for uninterrupted testing of the output signal

TECHNICAL DATA

The device conforms to the guidelines of DIN 41 494, Part 5 or IEC 297 and IEC 48 D (CO) 6

Application

by connection power supply unit or buffer amplifier

Transmitter circuit (with power supply unit)

Signal range 4 ... 20 mA

Supply voltage

(with 20 mA) 17 V

Protection class intrinsically safe / non-intrinsically safe

Input (with buffer amplifier)

Signal range 0 / 4 ... 20 mA

Voltage drop (at input) approx. 1 V

Protection class intrinsically safe / non-intrinsically safe

Output

Standard signal 0 / 4 ... 20 mA

Permissible load 0 ... 750 Ω

Load effect < 0.1 %

Residual ripple 1 % (amplitude)

Voltage signal 0 ... 10 V

Permissible Load 1 kΩ

Load effect < 0.1 %

Current limiting approx. 30 mA

LED in output circuit I_A operation indicator green if I_A 1 mA

(goes out when current measured at the test sockets)

Test sockets on front plate (2 mm connector)

Response characteristic

Response characteristic linear / square-root-extracted
Deviation

linear 0.1 %

square-root-extracted

5 ... 10 % 0.5 %

10 ... 100 % 0.2 %

Minimum value suppression

(with square-root-extr.) 8 % of output

Step response (as per VDI/VDE 2600)

linear approx. 100 ms

square-root-extracted approx. 200 ms

Temperature effect (0 ... 60 °C)

Zero / span for

linear 0.1 %/10 K

square-root-extracted

5 ... 10 % 0.4 %/10 K

10 ... 100 % 0.2 %/10 K

Effect of power supply (tolerance range)

Voltage / frequency 0.1 %

Galvanic separation from input or transmitter power supply circuit, output and power supply

Elektromagnetic compatibility EMC

Operating conditions industrial environment

Immunity according to

- EN 50 082-2 fulfilled ¹⁾

Emission according to

- EN 55 011,

Group 1, Class A fulfilled

- EN 50 081-2 fulfilled

NAMUR recommendation EMC, edition: May 1993

Power supply

AC / DC version AC / DC 24 V

AC voltage 24 V

Tolerance +15 %, -20 %
nominal

frequency range 50 ... 60 Hz

Tolerance 2 Hz

Power consumption

(within tolerance range). 4VA

Current consumption

(with 24 V) 160 mA

DC voltage 24V

Tolerance +30 %, -25%

Permissible residual

ripple V_{pp} 15 %

within tolerance range

Power consumption

(within tolerance range). 2.8VA

Current consumption

(with 24 V) 130 mA

Starting current < 1 A

Operating conditions (as per IEC 654-2)

The device can be operated with a power supply class a.c.4, d.c.4

Ambient conditions

Ambient temperature 0 ... +60 °C

Relative humidity 10 ... 75 %

Condensation none

Transport and storage

temperature -20 ... +70 °C

Service conditions (as per IEC 654-1)

The device can be operated at a location in class B2

Version

19" module, plug-in unit with printed circuit board in Eurocard format 100 x 160 mm

Front plate width 4 TE = 20.32 mm

Colour grey (RAL 7032)

Nominal position upright NL 90

Wight approx. 0.25 kg

Electrical connection Female multipoint connector as per DIN 41 612 type F, 32-pin, contact z and d

Connection options as per DIN 41 611, DIN 46 244

Connection type	Wire cross-section from ... to mm ²
Soldering	0.5 ... 1.5
Wire wrapping	0.4 ... 0.8
Clamping	0.5 ... 1.5
Crimp	0.5 ... 1.5
Clip pin 0.8 x 1.6	$\frac{\text{Au}^{2)} \text{ Sn}^{3)}$ 0.5 ... 1.5
Clip pin 0.8 x 2.4	$\frac{\text{Au}^{2)} \text{ Sn}^{3)}$ 0.2 ... 0.55
Flat push-on 2.8 x 0.8	0.25 ... 1.5

1) Acceptance criterion A: 1 % F. S.
Passing deviations > 1 % are possible

2) Au = thin gold-plated

3) Sn = tin-plated

TECHNICAL DATA (continued)

Protection

Shock-hazard protection . . . Protection class I as per IEC 348
 Fuses integrated in device
 Back-up fuse Protection against shock currents must be provided on the system side

CE marking

Electromagnetic compatibility 89/336/EWG

Nameplate inscription

In font IBM Courier 12:
 max. 3 lines, max. 6 characters/line
 In font IBM Orator 10:
 max. 2 lines, max. 6 characters/line

Explosion protection

Application	Type PTB-No.	Type of protection [EEx]		Certificate of conformity			Limit values		Connection to intrinsically safe circuits with max. values		
				Max. values			Limit values		U _{max.} [V]	I _{max.} [mA]	P _{max.} [mW]
				U _{max.} [V]	I _{max.} [mA]	P _{max.} [mW]	L _a max. [mH]	C _a max. [µF]			
Power supply unit	BSB 582 U Ex-86.B.2072X	ib	IIC	21	47	712	2	0.068	-		
			IIB				2.5	0.4			
Buffer amplifier		ib	IIC	1	47	12	15	200	40	100	2
			IIB				56	3000			

Coding for intrinsically safe circuits

For 19" modules with intrinsically safe circuits, the slots (in the rack or housing) must be protected by inserting the coding keys (device-specific) otherwise errors could occur. For devices of design BSB 582 U the coding keys for coding positions 9 and 13 are provided.

DIMENSIONS

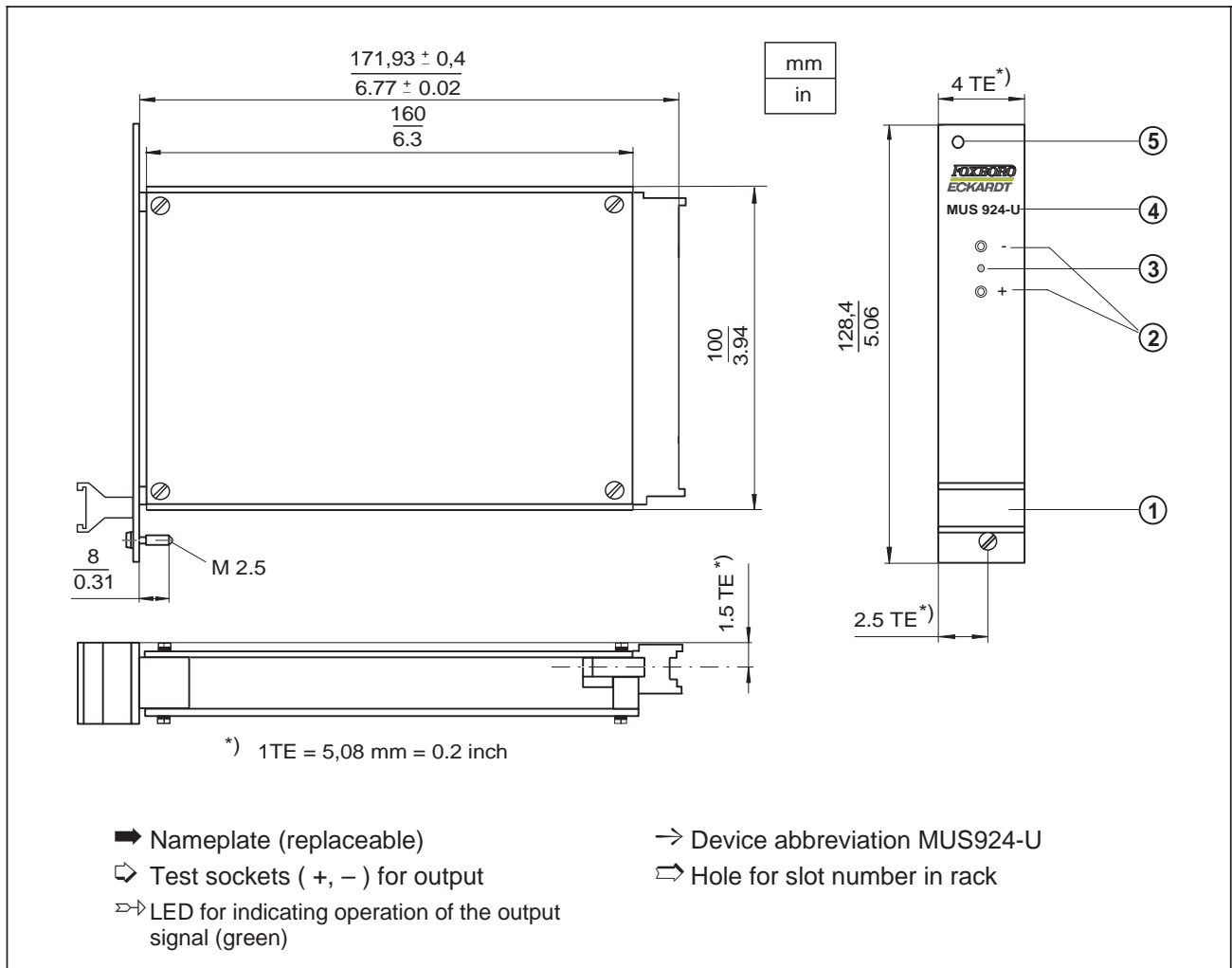

CONNECTION DIAGRAM

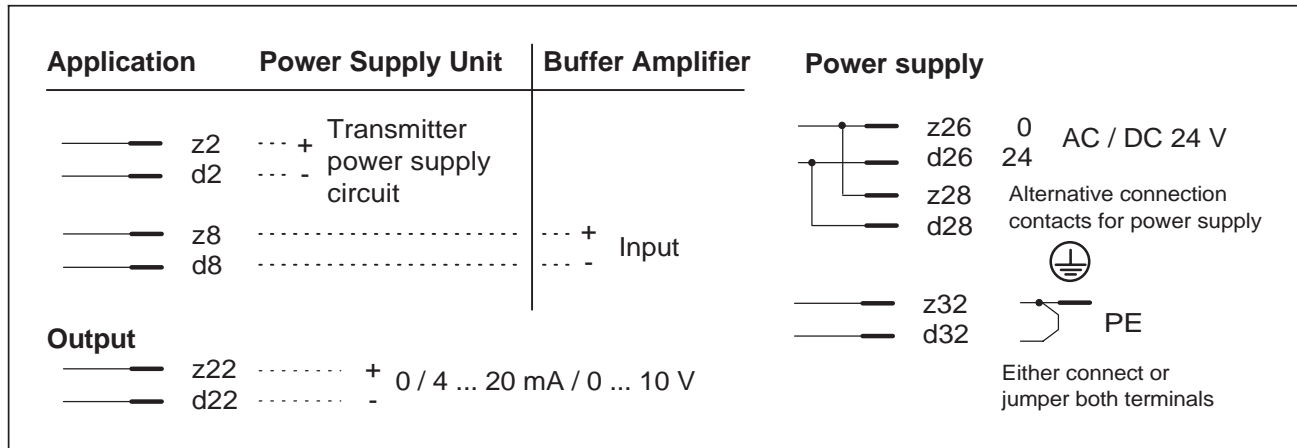

MODEL CODES

MUS924 Power Supply Unit / Buffer Amplifier 19"	
Version	
-U 1 Channel, MUS or TV	
Input	
A	0 to 20 mA (only as buffer amplifier)
B	4 to 20 mA
Output	
1	0 to 20 mA
2	4 to 20 mA
3	0 to 10 V
Characteristic type	
L	linear
R	square-root-extracted
Electrical Classification	
EGB	CENELEC [EEEx ib] IIC
ZZZ	not ex.proof or intrinsic safe
Optional Features	
-N Nameplate Inscription	
-P Coding Tool	
Accessory Connector with	
-1 Solder connections	
-2 Wire wrap connections	
-3 Screw terminals	
-4 Crimping connections	
-5 Au clip pin 0.8x1.6 connection	
-6 Sn clip pin 0.8x1.6 connection	
-7 Au clip pin 0.8x2.4 connection	
-8 Sn clip pin 0.8x2.4 connection	
-9 Flat push on connections 2.8x0.8	
MUS924	
Example Model Code: MUS924 -U B 2 L EGB -1	

Subject to alterations - reprinting, copying and translation prohibited. Products and publications are normally quoted here without reference to existing patents, registered utility models or trademarks. The lack of any such reference does not justify the assumption that a product or symbol is free.